

**DESPIECE TECNICO
SPARE PART DRAWING**

**Secadora
Dryer**

MODELO / MODEL:

SR-23

SR-23 MP-PSM



PLATON SERVICE
8 (800) 500-34-41
www.platonservice.com

Enero -January 2010



Fagor Industrial

ANALOGIC BODY
MUEBLE ANALOGICO
CARROZZERIA ANALOGICO
ENSEMBLE ANALOGIC
ANALOGKASTEN

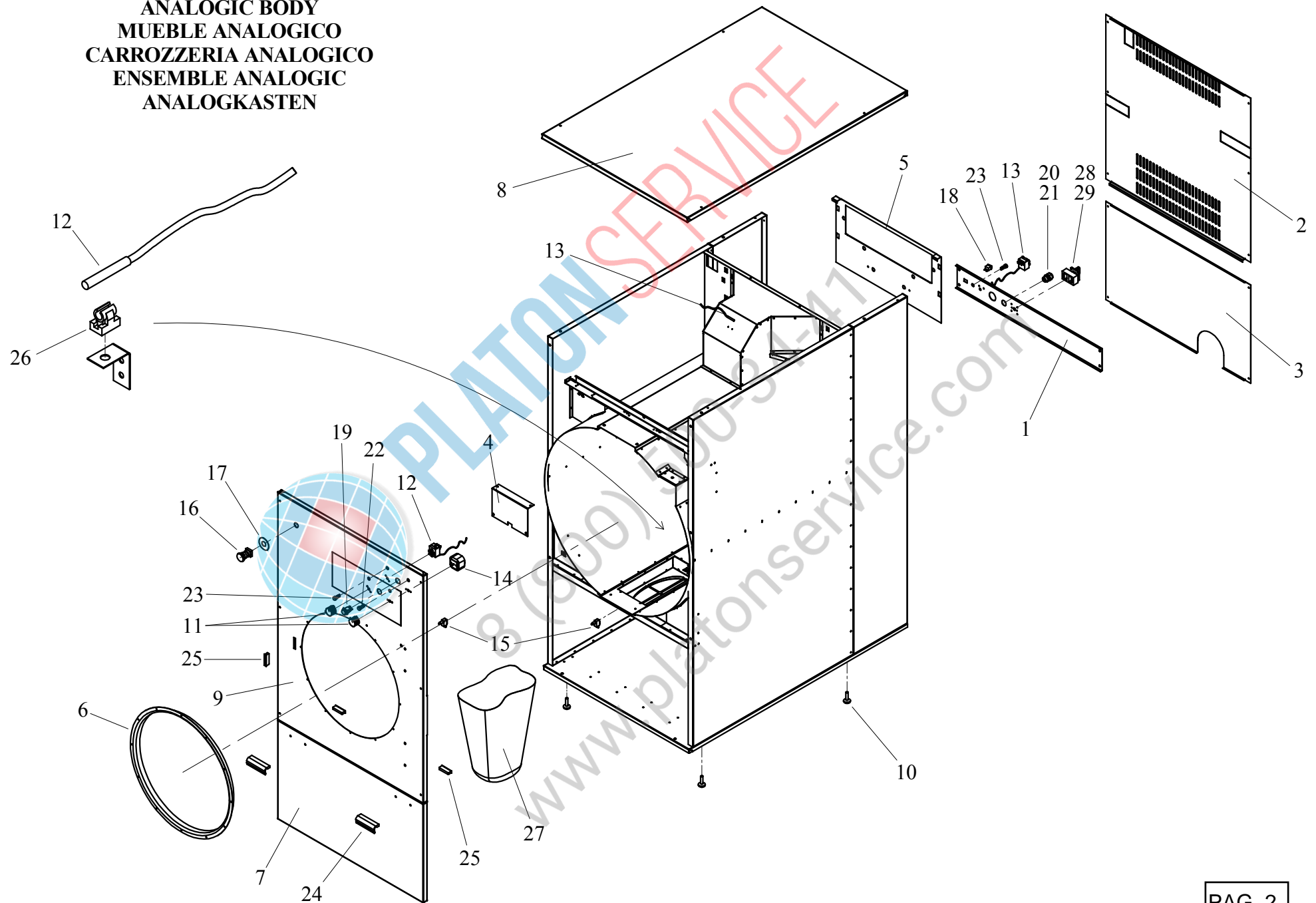

ANALOGIC BODY / MUEBLE ANALOGICO / CARROZZERIA ANALOGICO / ENSEMBLE ANALOGIC / ANALOGKASTEN (PAG.10)

Pos.	Código	23	Description	Descripción	Descrizione	Désignation	Bezeichnung
1	DO00V20023	1	Back lids reinforcement	Refuerzo tapas posteriores	Schiena centrale	Renfort couvercles arrière	Verstärkung hintere deckel
2	DO00V20028	1	Back superior lid	Tapa posterior superior	Schiena superiore	Couvercle arrière supérieur	Oberer hinterdeckel
3	DO00V20029	1	Back inferior lid	Tapa posterior inferior	Schiena inferiore	Couvercle arrière inférieur	Unterer hinterdeckel
4	DO00V20069	1	Front pannel joint	Unión tapa intermedia	Pannello ass.vasca/frontale	Assemble panneau frontale	Verbindung mitteldeckel
5	DO00V04003	1	Battery thermic protection lid	Tapa protección térmica batería	Pannello protezione termica	Couvercle protection thermique	Deckel thermoschutz der batterie
6	DO00V00053	1	Inlet hoop	Aro refuerzo entrada	Anello circolare carico oblò	Cercle entrée	Eingangverstärkungsring
7	DO07V20081	1	Fluff filter lid	Tapa filtro borra	Pannello ispezione filtro	Couvercle filtre bourre	Flugfilterdeckel
8	DO07V20068	1	Ceiling	Techo	Coperchio	Plafond	Plafond
9	DO07V20071	1	Analogic front pannel	Tapa intermedia analógica	Pannello frontale	Panneau frontale analogique	Analogischer mitteldeckel
10	DO1BC03036	4	Levelling feet	Pies nivelación	Piedini regolabili	Pieds de nivellement	Nivellierfüsse
11	DO1BJ07520	2	Thermostat timer	Mando reloj/termostato	Comando orologio/termostato	Pouvoir horloge/thermostat	Thermostat-zeitregler
12	DO1DG11130	1	Thermostat cap. 2,9 M.INV 90°	Termostato cap. 2,9 M.INV 90°	Termostato cap. 2,9 M.INV 90°	Thermostat cap. 2,9 M.INV 90°	Thermostat Kap. 2,9 M INV 90°
13	DO1DG11154	1	Safety thermostat 180°	Termostato seguridad 180°	Termostato sicurezza 180°	Thermostat sécurité 180°	Sicherheitsthermostat 180°
14	DO1DI13315	1	Clock with delay 60"	Reloj con retardador de 60"	Orologio con fa retardare 60"	Horloge avec retardateur 60"	Zeituhr verzögerung 60"
15	DO1DK13002	2	Safety micro	Micro seguridad	Micro di sicurezza	Micro sécurité	Sicherheitsmikroschalter
16	DO1DK13104	1	Emergency push-button	Pulsador paro emergencia	Pulsante emergenza completo	Bouton d'urgence	Notstoppdruckknopf
17	DO1DK13106	1	Emergency stop adhesive	Anagrama paro emergencia	Targa "Emergency Stop"	Anagramme arrêt d'urgence	Notstoppogramm
18	DO1DK13111	1	Reset rectanular button (Gas)	Pulsador reset rectangular (Gas)	Pulsante reset (Gas)	Bouton reset rectangulaire (Gaz)	Rechtekiger reset-druckknopf (Gas)
19	DO1DK13240	1	Green light push-button	Pulsador bipolar luminoso verde	Pulsante luce verde	Pulsateur bipolaire lumineux vert	Grünleuchtender bipolarer druckknopf
20	DO1DL15029	1	Caps top PG-29 (Electric)	Prensa estopa PG-29 (Electrico)	Passa cavo PG-29 (Electric)	Passe fil électrique PG-29 (Électrique)	Anschlussleitung PG-29 (Elektrische)
21	DO1DL15021	1	Caps top PG-16 (Gas-Steam)	Prensa estopa PG-16 (Gas-Vapor)	Passa cavo PG-16 (Gas-Vapore)	Passe fil électrique PG-16 (Gaz-Vapore)	Anschlussleitung PG-16 (Gas-dampfheizung)
22	DO1DL14313	1	Green pilot D13	Piloto D13 verde	Pilota D13 verde	Pilote D13 vert	Warnlampe grün D13
23	DO1DL14315	2	Red pilot D13	Piloto D13 rojo	Pilota D13 rosso	Pilote D13 rouge	Warnlampe rot D13
24	DO1FB03060	2	Fluff filter lid handle	Tirador tapa filtro borra	Maniglia pannello filtro	Poignée couvercle filtre bourre	Griff des flugfilterdeckels
25	DO1FB03075	3	Magnet band	Banda magnética	Profilo magnetico	Bande magnétique	Magnetband
26	DO1FB90220	1	Polypropilene clamp 6mm	Abrazadera polipropileno 6mm	Portasonda termostato in plastica	Collier polypropylène 6mm	Rohrschelle aus polypropylen 6mm
27	DO1SK00016	1	Fluff filter bag	Saco filtro borra	Sacco filtro aria	Sac filtre bourre	Flugfiltersack
28	DO1DK13252	1	Main switch 63A (Electric)	Interruptor general 63A (Electrico)	Interruttore sezionatore (Electric)	Interrupteur général 63A (Électrique)	Hauptschalter 63A (Elektrische)
29	DO1DK13258	1	Main switch 20A (Gas-Steam)	Interruptor general 20A (Gas-Vapor)	Interruttore sezionatore(Gas-Vapore)	Interrupteur général 20A(Gaz-Vapore)	Hauptschalter 20A (Gas-dampfheizung)

DIGITAL BODY
MUEBLE DIGITAL
CARROZZERIA DIGITAL
MEUBLE DIGITAL
DIGITALKASTEN

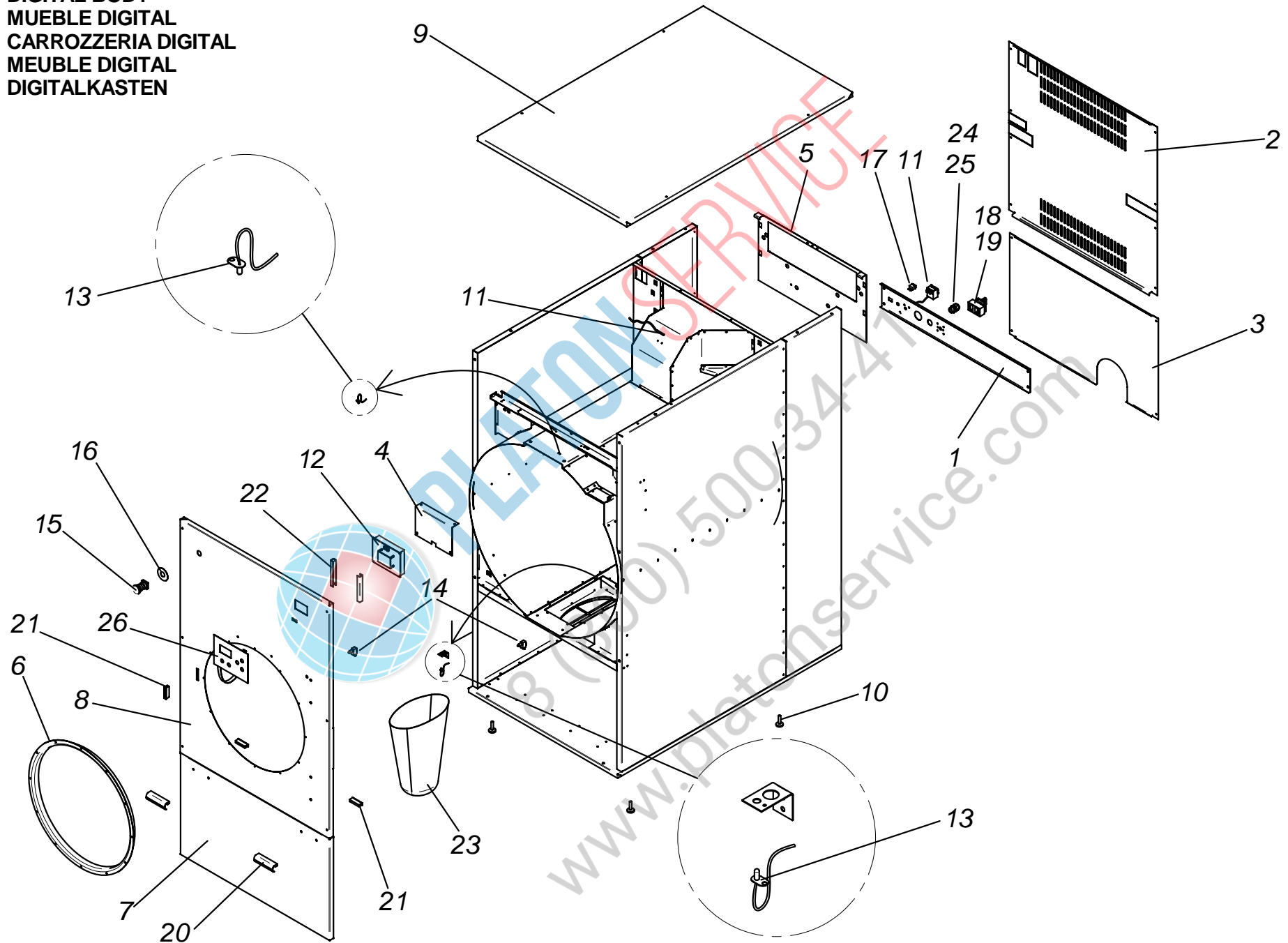

DIGITAL BODY / MUEBLE DIGITAL / CARROZZERIA DIGITAL / MEUBLE DIGITAL / DIGITALKASTEN (PAG.10) FAGOR

Pos.	Código	23	Description	Descripción	Descrizione	Désignation	Bezeichnung
1	DO00V20023	1	Back lids reinforcement	Refuerzo tapas posteriores	Schiena centrale	Renfort couvercles arrière	Verstärkung hintere deckel
2	DO00V20028	1	Back superior lid	Tapa posterior superior	Schiena superiore	Couvercle arrière supérieur	Oberer hinterdeckel
3	DO00V20029	1	Back inferior lid	Tapa posterior inferior	Schiena inferiore	Couvercle arrière inférieur	Unterer hinterdeckel
4	DO00V20069	1	Front panel joint	Unión tapa intermedia	Pannello ass.vasca/frontale	assemble panneau frontale	Verbindung mitteldeckel
5	DO00V04003	1	Battery thermic protection lid	Tapa protección térmica batería	Pannello protezione termica	Couvercle protection thermique	Deckel thermoschutz der batterie
6	DO00V00053	1	Inlet hoop	Aro refuerzo entrada	Anello circolare carico oblò	Cercle entrée	Eingangsverstärkungsring
7	DO07V20081	1	Fluff filter lid	Tapa filtro borra	Pannello ispezione filtro	Couvercle filtre bourre	Flugfilterdeckel
8	DO07V20128	1	Digital front panel	Tapa intermedia digital	Pannello frontale	Panneau frontale digitale	Digital mitteldeckel
9	DO07V20068	1	Ceiling	Techo	Coperchio	Plafond	Plafond
10	DO1BC03036	4	Levelling feet	Pies nivelación	Piedini regolabili	Pieds de nivellement	Nivellierfüsse
11	DO1DG11154	1	Safety thermostat 180°	Termostato seguridad 180°	Termostato di sicurezza	Thermostat sécurité 180°	Sicherheitsthermostat 180°
12	DO1DH12206	1	PSM microprocessor	Microprocesador PSM	Microprocessore PSM	Microprocesseur PSM	Mikroprozessor PSM
13	DO1DH12314	2	Micro. temperature sound	Sonda temperatura microprocesador	Sonda temperatura micro.	Sonde température microprocesseur	Temperaturfühler f.mikroprozessor
14	DO1DK13002	2	Safety micro	Micro seguridad	Micro di sicurezza	Micro sécurité	Sicherheitsmikroschalter
15	DO1DK13104	1	Emergency push-button	Pulsador paro emergencia	Pulsante emergenza completo	Bouton d'urgence	Notstoppdruckknopf
16	DO1DK13106	1	Emergency stop adhesive	Anagrama paro emergencia	Targa "Emergency Stop"	Anagramme arrêt d'urgence	Notstoppogramm
17	DO1DK13111	1	Reset rectangular button (Gas)	Pulsador reset rectangular (Gas)	Pulsante reset (Gas)	Bouton reset rectangulaire (Gaz)	Rechteckiger reset-druckknopf (Gas)
18	DO1DK13252	1	Main switch 63A (Electric)	Interruptor general 63A (Electrico)	Interruttore sezionatore (Electric)	Interrupteur général 63A (Électrique)	Hauptschalter 63A (Elektrische)
19	DO1DK13258	1	Main switch 20A (Gas-Steam)	Interruptor general 20A (Gas-Vapor)	Interruttore sezionatore(Gas-Vapore)	Interrupteur général 20A(Gaz-Vapore)	Hauptschalter 20A (Gas-dampfheizung)
20	DO1FB03060	2	Fluff filter lid handle	Tirador tapa filtro borra	Maniglia pannello filtro	Poignée couvercle filtre bourre	Griff des flugfilterdeckels
21	DO1FB03075	3	Magnet band	Banda magnética	Profilo magnetico	Bande magnétique	Magnetband
22	DO00V00126	2	Support of PSM microporcessor	Soporte microprocesador PSM	Sostegno microprocessore PSM	Support du microprocesseur PSM	Ständer für den Mikroprozessor PSM
23	DO1SK00016	1	Fluff filter bag	Saco filtro borra	Sacco filtro aria	Sac filtre bourre	Flugfiltersack
24	DO1DL15029	1	Caps top PG-29 (Electric)	Prensa estopa PG-29 (Electrico)	Passa cavo PG-29 (Electric)	Passe fil électrique PG-29 (Électrique)	Anschlussleitung PG-29 (Elektrische)
25	DO1DL15021	1	Caps top PG-16 (Gas-Steam)	Prensa estopa PG-16 (Gas-Vapor)	Passa cavo PG-16 (Gas-Vapore)	Passe fil électrique PG-16 (Gaz-Vapore)	Anschlussleitung PG-16 (Gas-dampfheizung)
26	DO1BH07023	1	Stiker	Stiker	Stiker	Stiker	Stiker

ANALOGIC ELECTRIC BOX / CUADRO ELECTRICO ANALOGICO / QUADRO ELETTRICO ANALOGICO / TABLEAU ELECTRIQUE ANALOGIC / ANALOGSCHALTTAFEL
ELECTRICAL HEATING/ CALEFACCION ELECTRICA / RISCALDAMENTO ELETTRICO/CHAUFFAGE ELECTRIQUE/ ELEKTRISCHE HEIZUNG

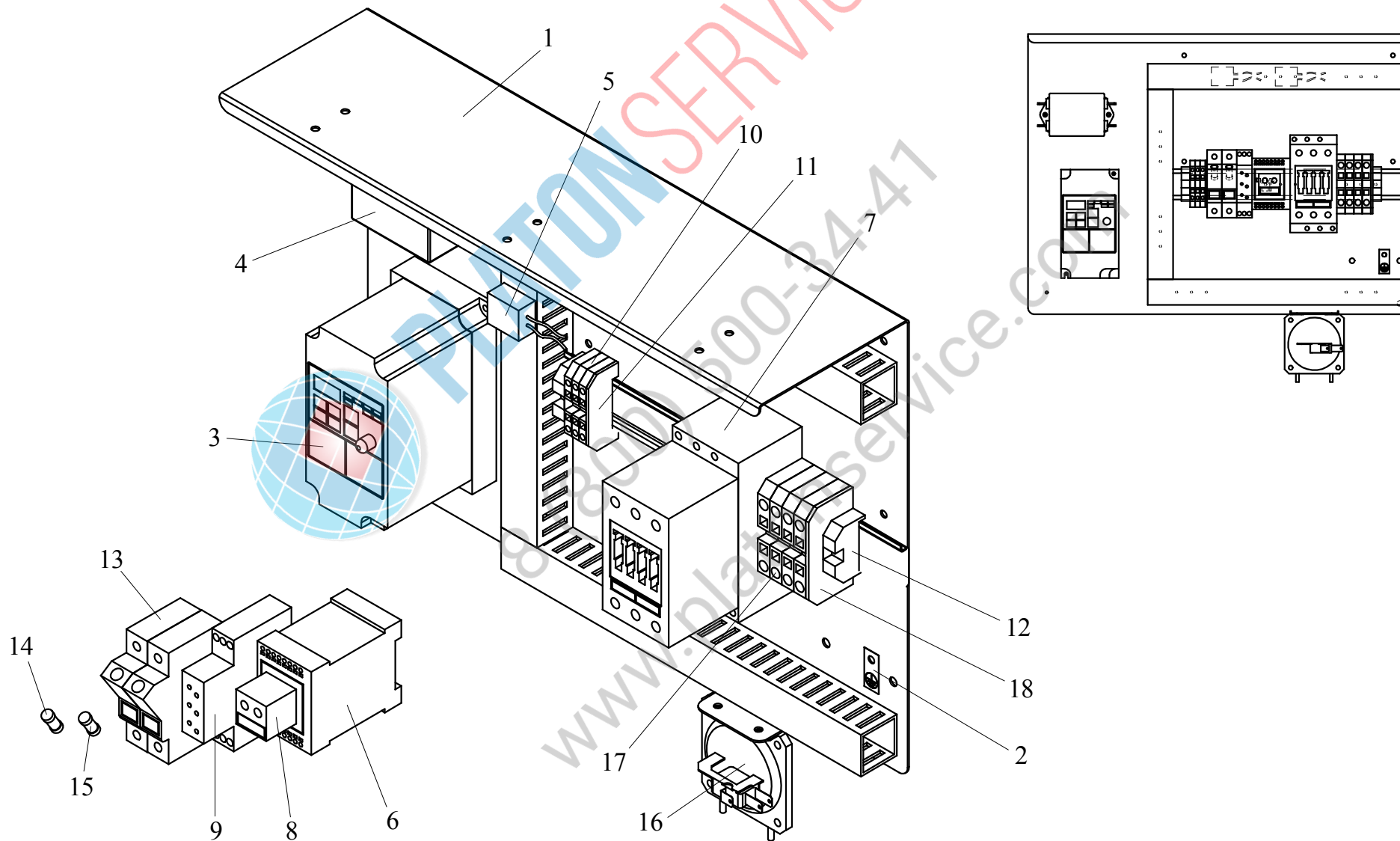

ANALOGIC ELECTRIC BOX / CUADRO ELECTRICO ANALOGICO/ QUADRO ELETTRICO ANALOGICO / TABLEAU ELECTRIQUE ANALOGIC / ANALOGSCHALTТАFEL (PAG.12)
ELECTRICAL HEATING / CALEFACCION ELECTRICA / RISCALDAMENTO ELETTRICO / CHAUFFAGE ELECTRIQUE / ELEKTRISCHE HEIZUNG

Pos.	Código	23	Description	Descripción	Descrizione	Désignation	Bezeichnung
1	DO00V00024	1	Electric box	Cuadro eléctrico	Piastra porta cablaggio	Tableau électrique	Schalttafel
2	DO1BH07277	1	Earth indicator	Indicador tierra	Targa di terra	Indicateur terre	Erdungszeiger
3	DO1DC00074	1	Frequency control 0,25 kW	Variador frecuencia 0,25 kW	Variatore di frequenza 0,25 kW	Variateur fréquence 0,25 kW	Frequenzumformer 0,25 kW
4	DO1DC01010	1	Feeding filter	Filtro alimentación	Filtro di linea	Filtre alimentation	Zuführungsfilter
5	DO1DC01050	2	Universal RC filter 220V	Filtro RC universal 220V	Filtro RC 220V	Filtre RC universel 220V	Universal RC filter 220V
6	DO1DF10130	1	Fan contactor	Contacto ventilador	Mini contattore	Contacteur ventilateur	Schaltenschutz ventilator
7	DO1DF10135	1	Resistors contactor	Contacto resistencias	Contattore resistenze	Contacteur résistances	Schaltenschutz widerstand
8	DO1DF10240	1	Auxiliar contact	Contacto auxiliar	Contacto ausiliare	Contacte auxiliar	Auxiliar kontakt
9	DO1DI12320	1	Timer 4 functions	Temporizador 4 funciones	Funzioni del temporizzatore	Temporisateur	Funktionen des timers
10	DO1DL14150	3	Connection boxes 4/6 mm	Regleta conexión 4/6 mm	Connettore plastica 4/6 mm	Réglette connexion 4/6 mm	Anschlussleiste 4/6 mm
11	DO1DL14156	1	Boxes lid 4/6 mm	Tapa regleta 4/6 mm	Fianco di chiusura 4/6 mm	Plateau réglette 4/6 mm	Deckel f.Anschlussleiste 4/6 mm
12	DO1DL14162	2	End stop	Tope final	Terminale plastica	Arrêtoir final	Endstopp
13	DO1DL14203	2	Fuse housing lane 35	Portafusible carril 35	Portafusibile 8,5x31,5	Porte-fusible rail 35	Sicherungshalter schiene 35
14	DO1DL14280	2	Fuse cartridge 2Amp	Cartucho fusible 2Amp	Fusibile ceramica 2Amp	Cartouche fusible 2Amp	Sicherungspatrone 2Amp
15	DO1DL14282	2	Fuse cartridge 6Amp	Cartucho fusible 6Amp	Fusibile ceramica 6Amp	Cartouche fusible 6Amp	Sicherungspatrone 6Amp
16	DO1AB01439	1	Diferential air pressure	Presostato diferencial	Pressostato differenziale	Pressostat différentiel	Differentialdruckmesser
17	DO1DL14151	4	Connection boxes 10 mm	Regleta conexión 10 mm	Connettore plastica 10 mm	Réglette connexion 10 mm	Anschlussleiste 10 mm
18	DO1DL14157	1	Boxes lid 10 mm	Tapa regleta 10 mm	Fianco di chiusura 10 mm	Plateau réglette 10 mm	Deckel f.Anschlussleiste 10 mm

ANALOGIC ELECTRIC BOX / CUADRO ELECTRICO ANALOGICO / QUADRO ELETTRICO ANALOGICO / TABLEAU ELECTRIQUE ANALOGIC / ANALOGSHALTTAFEL
GAS-STEAM HEATING / CALEFACCION GAS-VAPOR / RISCALDAMENTO GAS-VAPORE / CHAUFFAGE GAZ-VAPEUR / GAS-DAMPFHEIZUNG

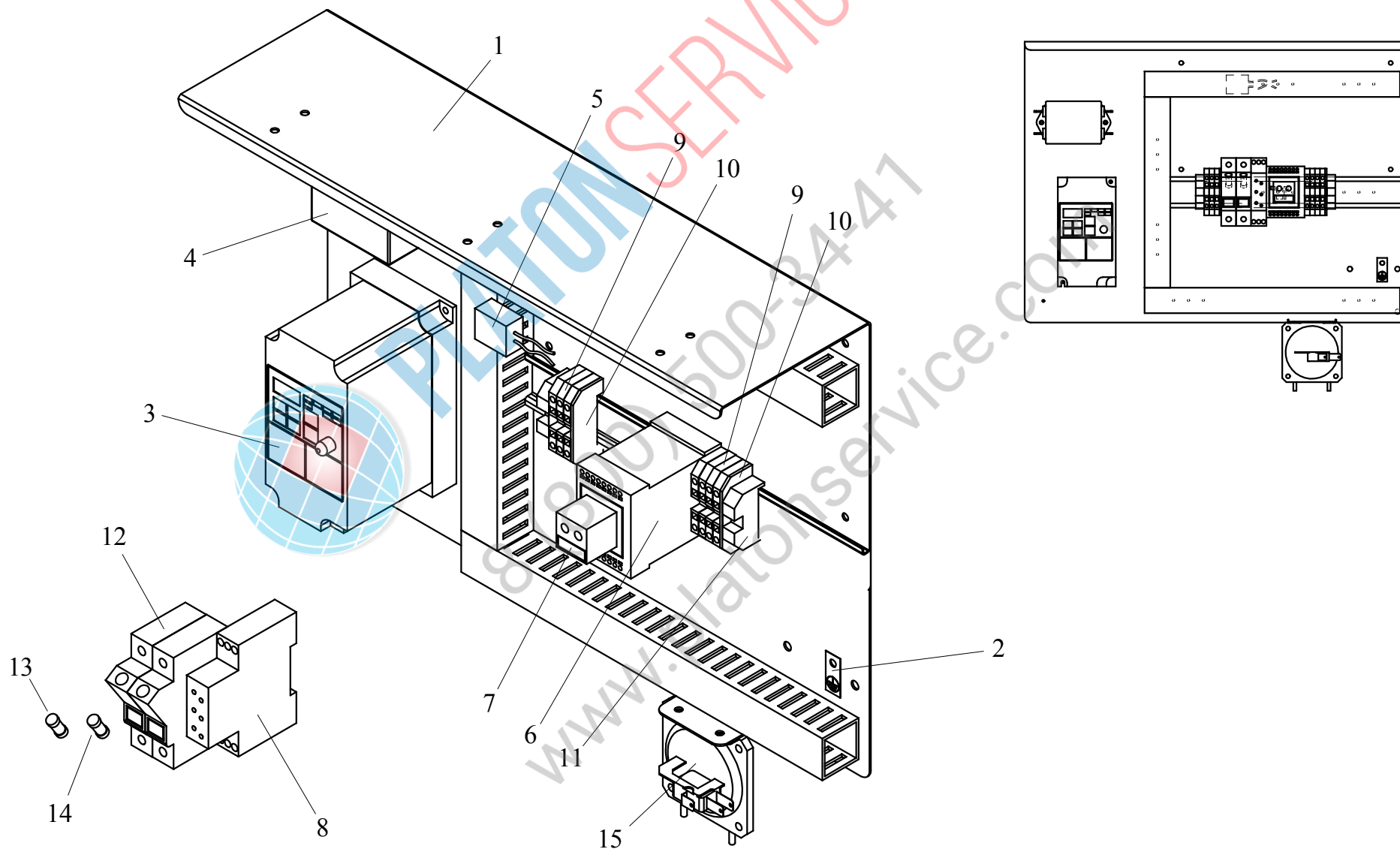

ANALOGIC ELECTRIC BOX / CUADRO ELECTRICO ANALOGICO/ QUADRO ELETTRICO ANALOGICO / TABLEAU ELECTRIQUE ANALOGIC / ANALOGSCHALTZTADEL (PAG.14)
 GAS-STEAM HEATING / CALEFACCION GAS-VAPOR / RISCALDAMENTO GAS-VAPORE / CHAUFFAGE GAZ-VAPEUR / GAS-DAMPFHEIZUNG

Pos.	Código	23	Description	Descripción	Descrizione	Désignation	Bezeichnung
1	DO00V00024	1	Electric box	Cuadro eléctrico	Piastra porta cablaggio	Tableau électrique	Schalttafel
2	DO1BH07277	1	Earth indicator	Indicador tierra	Targa di terra	Indicateur terre	Erdungszeiger
3	DO1DC00074	1	Frequency control 0,25 kW	Variador frecuencia 0,25 kW	Variatore di frequenza 0,25 kW	Variateur fréquence 0,25 kW	Frequenzumformer 0,25 kW
4	DO1DC01010	1	Feeding filter	Filtro alimentación	Filtro di linea	Filtre alimentation	Zuführungsfilter
5	DO1DC01050	1	Universal RC filter 220V	Filtro RC universal 220V	Filtro RC 220V	Filtre RC universel 220V	Universal RC filter 220V
6	DO1DF10130	1	Fan contactor	Contacto ventilador	Mini contattore	Contacteur ventilateur	Schaltenschutz ventilator
7	DO1DF10240	1	Auxiliar contact	Contacto auxiliar	Contacto ausiliare	Contacte auxiliar	Auxiliar kontakt
8	DO1DI12320	1	Timer 4 functions	Temporizador 4 funciones	Funzioni del temporizzatore	Temporisateur	Funktionen des timers
9	DO1DL14150	5	Connection boxes 4/6 mm	Regleta conexión 4/6 mm	Connettore plastica 4/6 mm	Réglette connexion 4/6 mm	Anschlussleiste 4/6 mm
10	DO1DL14156	2	Boxes lid 4/6 mm	Tapa regleta 4/6 mm	Fianco di chiusura 4/6 mm	Plateau réglette 4/6 mm	Deckel f. Anschlussleiste 4/6 mm
11	DO1DL14162	2	End stop	Tope final	Terminale plastica	Arrêtoir final	Endstopp
12	DO1DL14203	2	Fuse housing lane 35	Portafusible carril 35	Portafusibile 8,5x31,5	Porte-fusible rail 35	Sicherungshalter schiene 35
13	DO1DL14280	2	Fuse cartridge 2Amp	Cartucho fusible 2Amp	Fusibile ceramica 2Amp	Cartouche fusible 2Amp	Sicherungspatrone 2Amp
14	DO1DL14282	2	Fuse cartridge 6Amp	Cartucho fusible 6Amp	Fusibile ceramica 6Amp	Cartouche fusible 6Amp	Sicherungspatrone 6Amp
15	DO1AB01439	1	Diferential air pressure	Presostato diferencial	Pressostato differenziale	Pressostat différentiel	Differentialdruckmesser

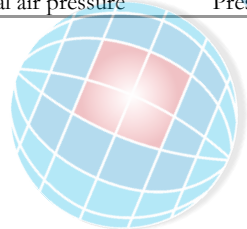

8 (800) 557-34-41
 www.platonservice.com

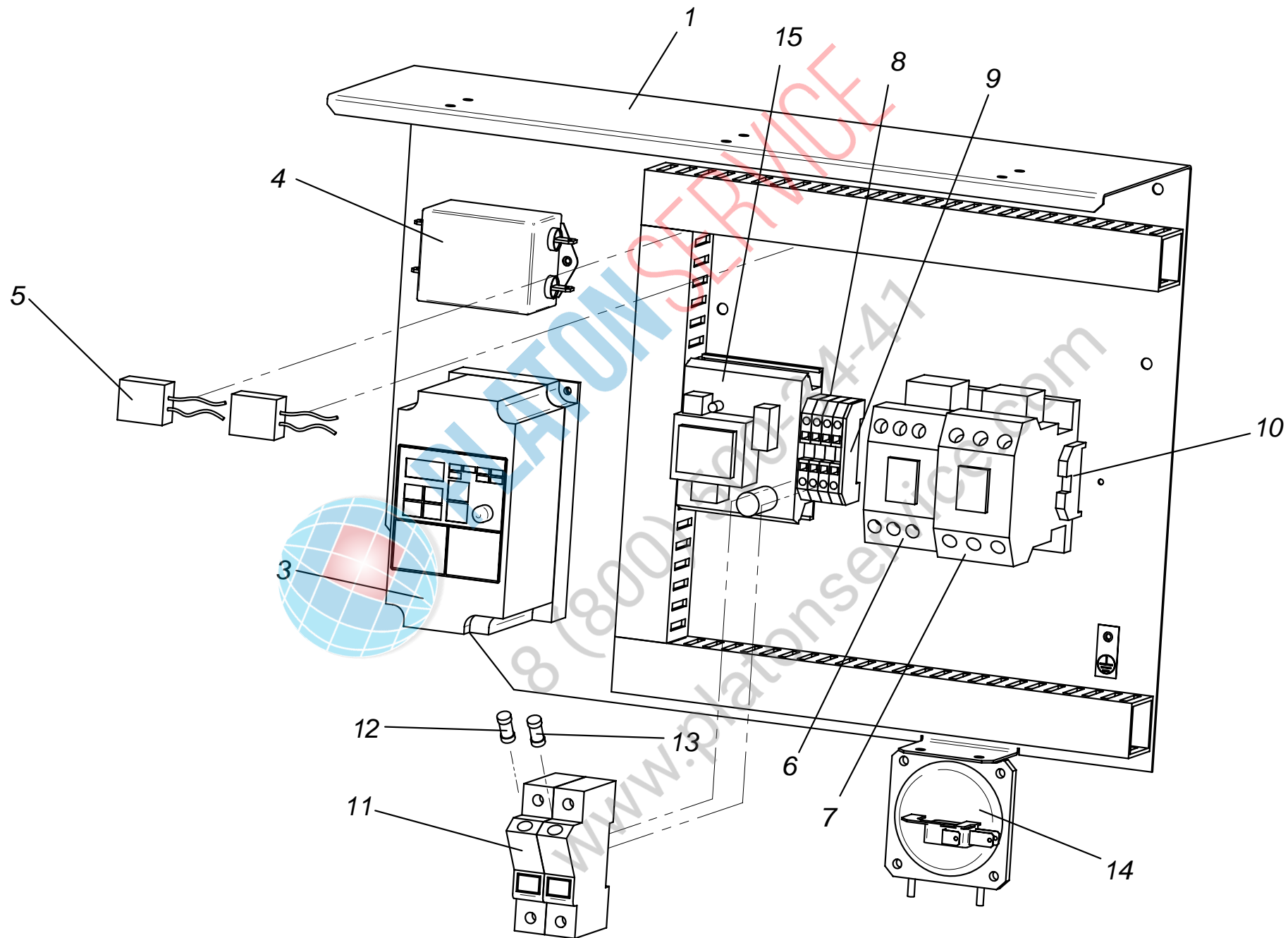

**DIGITAL ELECTRIC BOX / CUADRO ELECTRICO DIGITAL / QUADRO ELETTRICO / TABLEAU ELECTRIQUE DIGITAL / DIGITALSCHALTТАFEL (PAG.12)
ELECTRICAL HEATING / CALEFACCION ELECTRICA / RISCALDAMENTO ELETTRICO / CHAUFFAGE ELECTRIQUE / ELEKTRISCHE HEIZUNG**

Pos.	Código	23	Description	Descripción	Descrizione	Désignation	Bezeichnung
1	DO00V00024	1	Electric box	Cuadro eléctrico	Piastra porta cablaggio	Tableau électrique	Schalttafel
3	DO1DC00074	1	Frequency control 0,25 kW	Variador frecuencia 0,25 kW	Variatore di frequenza 0,25kW	Variateur fréquence 0,25 kW	Frequenzumformer 0,25 kW
4	DO1DC01010	1	Feeding filter	Filtro alimentación	Filtro di linea	Filtre alimentation	Zuführungsfilter
5	DO1DC01050	2	Universal RC filter 220V	Filtro RC universal 220V	Filtro RC 220V	Filtre RC universel 220V	Universal RC Filter 220V
6	DO1DF10131	1	Fan contactor	Contacto ventilador	Mini contattore	Contacteur ventilateur	Schaltenschutz ventilator
7	DO1DF10136	1	Resistors contactor	Contacto resistencias	Contattore resistenze	Contacteur résistances	Schaltenschutz Widerstand
8	DO1DL14150	4	Connection boxes 4/6 mm	Regleta conexión 4/6 mm	Connettore plastica 4/6 mm	Réglette connexion 4/6 mm	Anschlussleiste 4/6 mm
9	DO1DL14156	1	Boxes lid 4/6 mm	Tapa regleta 4/6 mm	Fianco di chiusura 4/6 mm	Plateau réglette 4/6 mm	Deckel f. Anschlussleiste 4/6 mm
10	DO1DL14162	1	End stop	Tope final	Terminale plastica	Arrêtoir final	Endstopp
11	DO1DL14203	2	Fuse housing lane 35	Portafusible carril 35	Portafusibile 8,5x31,5	Porte-fusible rail 35	Sicherungshalter schiene 35
12	DO1DL14280	2	Fuse cartridge 2Amp	Cartucho fusible 2Amp	Fusibile ceramica 2Amp	Cartouche fusible 2Amp	Sicherungspatrone 2Amp
13	DO1DL14282	2	Fuse cartridge 6Amp	Cartucho fusible 6Amp	Fusibile ceramica 6Amp	Cartouche fusible 6Amp	Sicherungspatrone 6Amp
14	DO1AB01439	1	Diferential air pressure	Presostato diferencial	Pressostato differenziale	Pressostat différentiel	Differentialdruckmesser
15	DO1DH12207	1	Source of electricity	Fuente alimentación	Alimentatore	Alimentation électrique	Netzteil



8 (800) 50034-4
www.platonservice.com

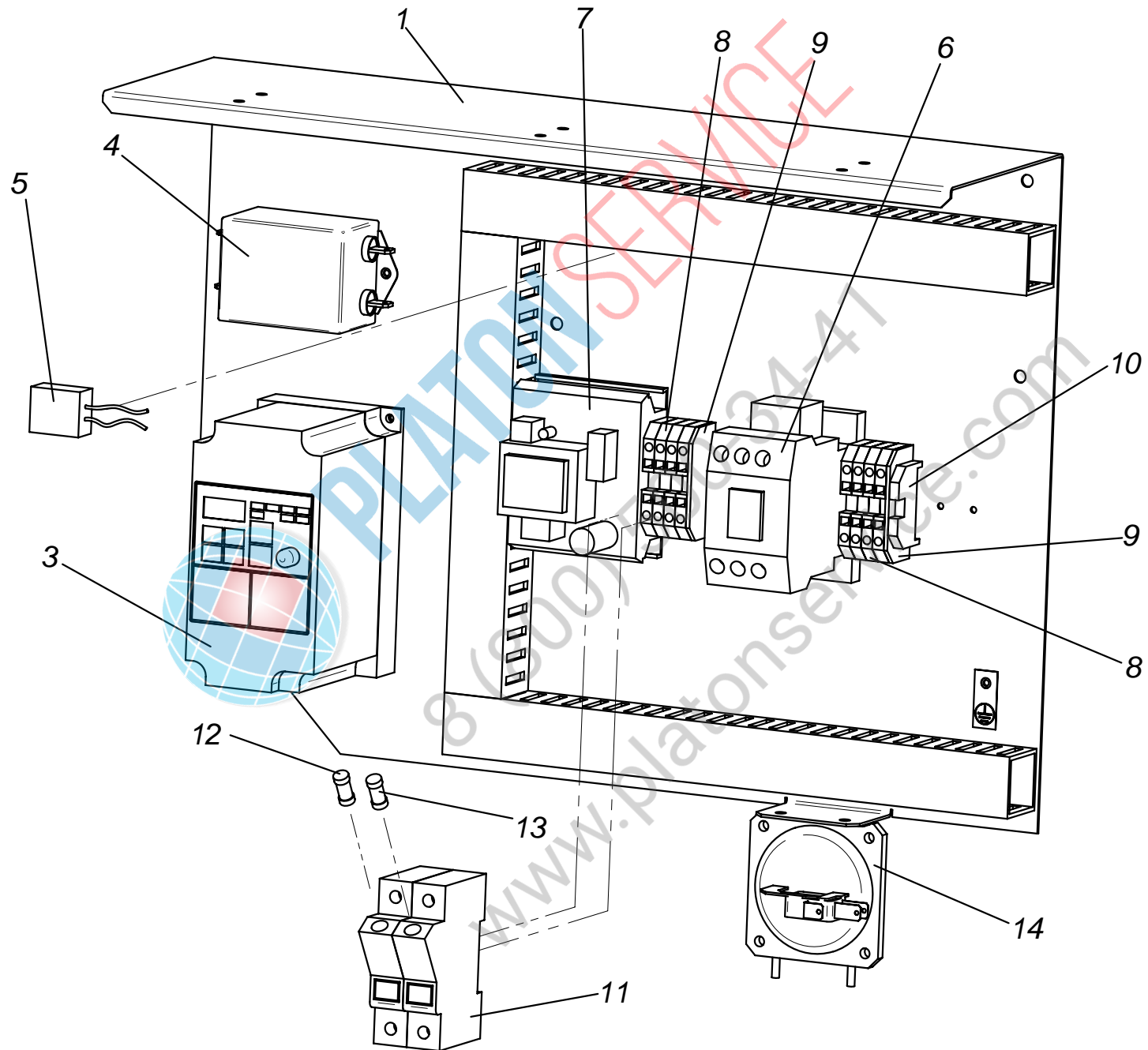

**DIGITAL ELECTRIC BOX / CUADRO ELECTRICO DIGITAL / QUADRO ELETTRICO / TABLEAU ELECTRIQUE DIGITAL / DIGITALSCHALTTFEL (PAG.14)
GAS-STEAM FEATING / CALEFACCION GAS-VAPOR / RISCALDAMENTO GAS-VAPORE / CHAUFFAGE GAZ-VAPEUR / GAS-DAMPFHEIZUNG**

Pos.	Código	23	Description	Descripción	Descrizione	Désignation	Bezeichnung
1	DO00V00024	1	Electric box	Cuadro eléctrico	Piastra porta cablaggio	Tableau électrique	Schalttafel
3	DO1DC00074	1	Frequency control 0,25 kW	Variador frecuencia 0,25 kW	Variatore di frequenza 0,25 kW	Variateur fréquence 0,25 kW	Frequenzumformer 0,25 kW
4	DO1DC01010	1	Feeding filter	Filtro alimentación	Filtro di linea	Filtre alimentation	Zuführensfilter
5	DO1DC01050	1	Universal RC filter 220V	Filtro RC universal 220V	Filtro RC 220V	Filtre RC universel 220V	Universal RC filter 220V
6	DO1DF10131	1	Fan contactor	Contacto ventilador	Mini contattore	Contacteur ventilateur	Schalterschutz ventilator
7	DO1DH12207	1	Source of electricity	Fuente alimentación	Alimentatore	Alimentation électrique	Netzteil
8	DO1DL14150	6	Connection boxes 4/6 mm	Regleta conexión 4/6 mm	Connettore plastica 4/6 mm	Réglette connexion 4/6 mm	Anschlussleiste 4/6 mm
9	DO1DL14156	2	Boxes lid 4/6 mm	Tapa regleta 4/6 mm	Fianco di chiusura 4/6 mm	Plateau réglette 4/6 mm	Deckel f.anchlussleiste 4/6 mm
10	DO1DL14162	1	End stop	Tope final	Terminale plastica	Arrêtoir final	Endstopp
11	DO1DL14203	2	Fuse housing lane 35	Portafusible carril 35	Portafisibile 8,5x31,5	Porte-fusible rail 35	Sicherungshalter schiene 35
12	DO1DL14280	2	Fuse cartridge 2Amp	Cartucho fusible 2Amp	Fusibile ceramica 2Amp	Cartouche fusible 2Amp	Sicherungspatrone 2Amp
13	DO1DL14282	2	Fuse cartridge 6Amp	Cartucho fusible 6Amp	Fusibile ceramica 6Amp	Cartouche fusible 6Amp	Sicherungspatrone 6Amp
14	DO1AB01439	1	Diferential air pressure	Presostato diferencial	Pressostato differenziale	Pressostat différentiel	Differentialdruckmesser



8 (800) 503441
www.platonservice.com

ELECTRICAL HEATING / BATERIA ELECTRICA / BATERIA ELETTRICA / CHAUFFAGE ELECTRIQUE / ELEKTRISCHE HEIZUNG

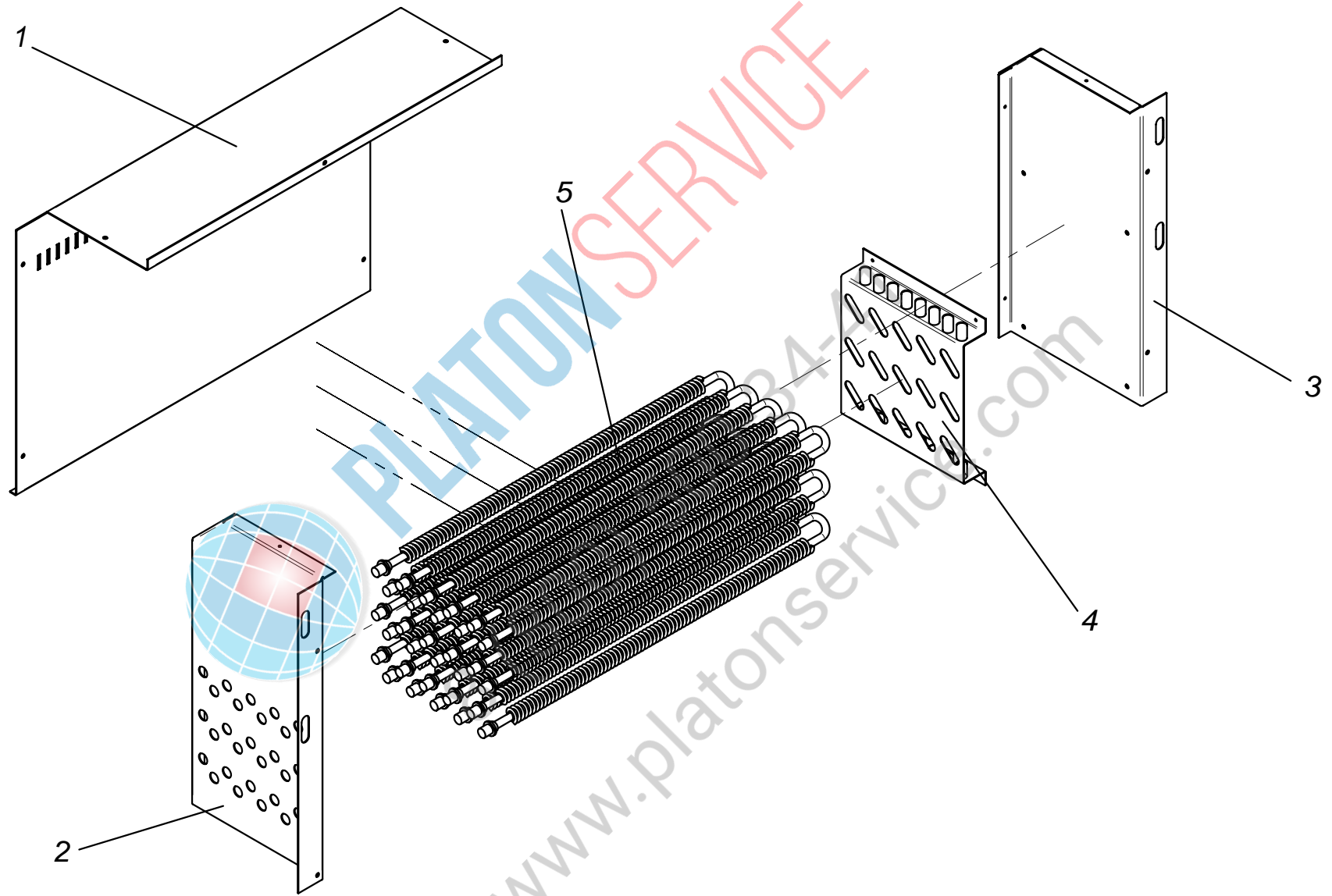

ELECTRICAL HEATING / BATERIA ELECTRICA / BATTERIA ELETTRICA / CHAUFFAGE ELECTRIQUE / ELEKTRISCHE HEIZUNG (PAG.13)

Pos.	Código	23	Description	Descripción	Descrizione	Désignation	Bezeichnung
1	DO00V23010	1	Electric battery box	Caja batería eléctrica	Schiena batteria elettrica	Boîte batterie électrique	Elektrische batterie gehäuse
2	DO00V23011	1	Electric battery right hand side	Lateral derecho batería eléctrica	Fianco sinistro batteria elettrica	Côté droit batterie électrique	Elektrische batterie rechte seite
3	DO00V23012	1	Electric battery left hand side	Lateral izquierdo batería eléctrica	Fianco destro batteria elettrica	Côté gauche batterie électrique	Elektrische batterie linke seite
4	DO00V23014	1	Resistor support	Soporte de resistencias	Sostegno resistenze	Support de résistances	Widerstands Ständer
5	DO1AC02259	15	Resistor 2000 W	Resistencia 2000 W	Resistenza 2000 W	Résistance 2000 W	Widerstand 2000 W



PLATON SERVICE
 8 (800) 500-34-41
 www.platonservice.com

GAS HEATING / BATERIA GAS / BATTERIA GAS / CHAUFFAGE GAZ / GASHEIZUNG

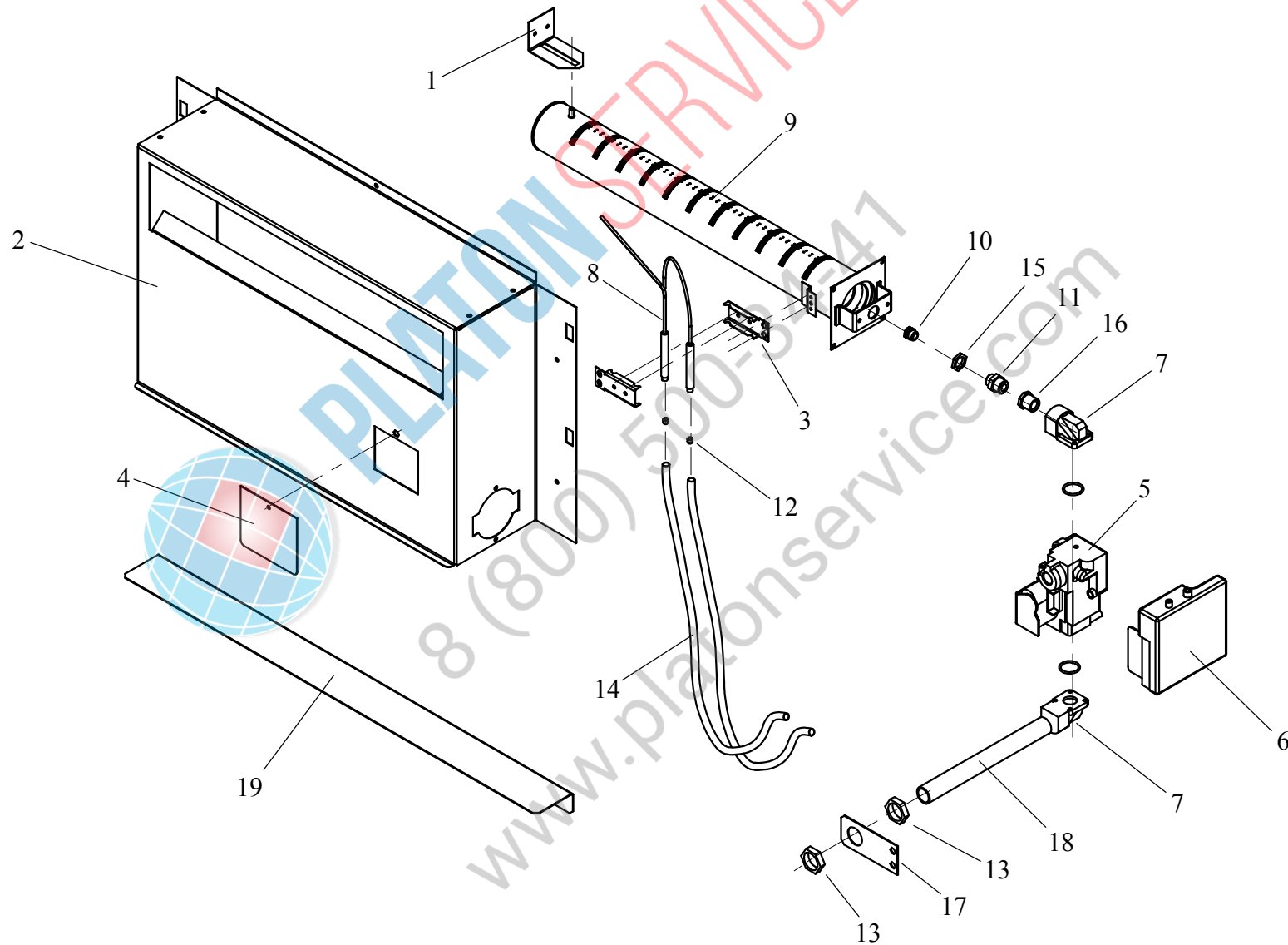

GAS HEATING / BATERIA GAS / BATTERIA GAS / CHAUFFAGE GAZ / GASHEIZUNG (PAG.18)

Pos.	Código	23	Description	Descripción	Descrizione	Désignation	Bezeichnung
1	DO00V04005	1	Gas burner support	Soporte quemador gas	Supporto bruciatore	Support brûleur gaz	Gasbrennerhalterung
2	DO01V24007	1	Gas box	Caja gas	Cassetto gas	Boîte gaz	Gascasten
3	DO01V04006	2	Electrode support	Soporte electrodos	Supporto elettrodi gas	Support electrode	Elektrodenhalter
4	DO010Y0404	1	Gas box window	Ventana caja gas	Sportello ispezione fiamma	Hublot boîte gaz	Fenster gascasten
5	DO1AB01415	1	Gas electrovalve	Electroválvula gas	Elettrovalvola gas	Electrovanne gaz	Elektroventil f.gas
6	DO1AB01416	1	Ionization circuit	Circuito ionización	Basetta elettronica	Circuit ionisation	Ionisationskreis
7	DO1AB01418	2	Aluminium conection 90° 1/2"	Racor aluminio 90° 1/2"	Raccordo alluminio 90° 1/2"	Raccord aluminium 90° 1/2"	Alu-verschraubung 90° 1/2"
8	DO1AB01490	2	Electrode	Electrodo	Elettrodo	Electrode	Elektrode
9	DO1AB01622	1	Gas burner	Quemador gas	Bruciatore gas	Brûleur gaz	Gasbrenner
10	DO1AB01668	1	Injector 2,7 mm (GLP)	Inyector 2,7 mm (Gas propano)	Ugello gas GLP 270	Injecteur 2,7 mm (Gas propane)	Injektor 2,7 mm (Propangas)
	DO1AB01670	1	Injector 4,8 mm (Natural gas)	Inyector 4,8 mm (Gas natural)	Ugello gas metano 480	Injecteur 4,8 mm (gaz naturel)	Injektor 4,8 mm (Erdgas)
11	DO1AB01671	1	Support injector	Porta inyector	Supporto ugello	Support injecteur	Injektorhalter
12	DO1DK00002	2	Electrode conector	Terminal electrodos	Connettore elettrodo	Connecteur electrode	Elektrodenanschluss
13	DO50797010	2	Against stainless nut 1/2"	Contra tuerca inoxidable 1/2"	Contro il dado inossidabile	Contre noix inoxydable 1/2"	Gegen rostfreie nub 1/2"
14	DO1DO02030	0,7	Electrode cable	Cable para bujía	Cavo alta tensione	Cable electrode	Kabel für elektrode
15	DO1TN10016	1	Nut M16x1	Tuerca M16x1 latón	Dado M16x1	Écrou M16x1	Messingmutter M16x1
16	DO50782411	1	Connection Fig.241 1/2" 3/8"	Reducción latón Fig.241 1/2" 3/8"	Raccordo Fig.241 1/2" 3/8"	Raccord Fig.241 1/2" 3/8"	Reduktionsverschr Fig.241 1/2" 3/8"
17	DO00V04007	1	Support tube exit gas	Soporte tubo salida gas	Gas dell'uscita del tubo	Support tube sortie gaz	Unterstützungsschlauchausgang gas
18	DO00V24010	1	Tube exit gas	Tubo salida gas	Gas dell'uscita del tubo	Tube sortie gaz	Schlauchausgang gas
19	DO01V24011	1	Gas box angle	Angulo entrada caja gas	Angulo cassetto gas	Angle boîte gaz	Gascaste Winkel

STEAM HEATING / BATERIA VAPOR / BATTERIA VAPORE / CHAUFFAGE VAPEUR / DAMPFHEIZUNG

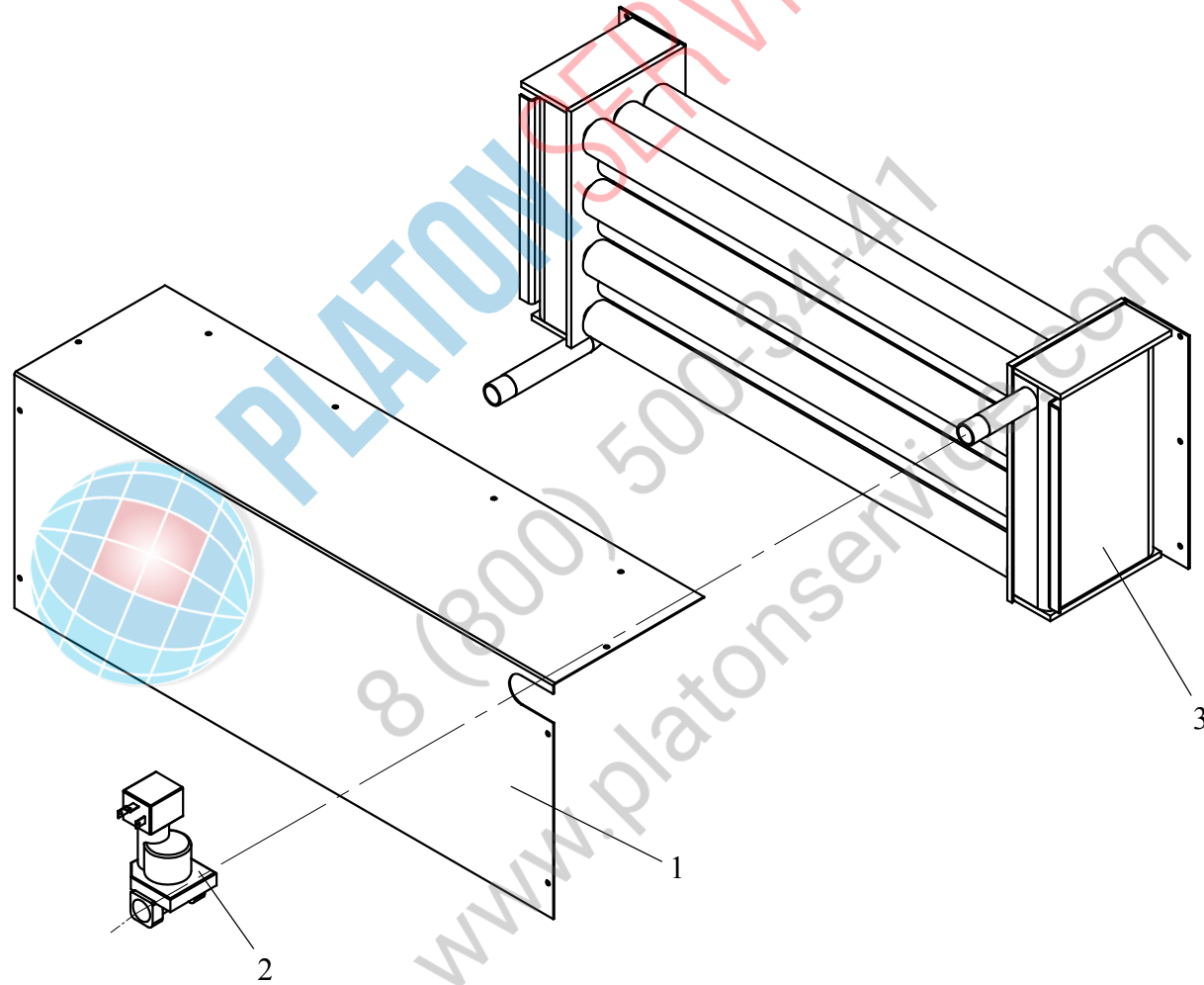

STEAM HEATING / BATERIA VAPOR / BATTERIA VAPORE / CHAUFFAGE VAPEUR / DAMPFHEIZUNG (PAG.20)

Pos.	Código	23	Description	Descripción	Descrizione	Désignation	Bezeichnung
1	DO00V25001	1	Steam battery cover	Tapa batería vapor	Coperchio batteria vapore	Couverture batterie vapeur	Dampfbatterie deckel
2	DO1JE80207	1	Steam electrovalve 1/2"	Electroválvula 1/2"	Elettrovalvola vapore 1/2"	Electrovanne vapeur 1/2"	Elektroventil 1/2"
3	DO800V2500	1	Steam battery set	Conjunto batería vapor	Batteria vapore	Ensemble batterie vapeur	Dampfbatterie kompl.



PLATON SERVICE

8 (800) 500-34-41

www.platonservice.com

DOOR / PUERTA / PORTA / PORTE / TÜR

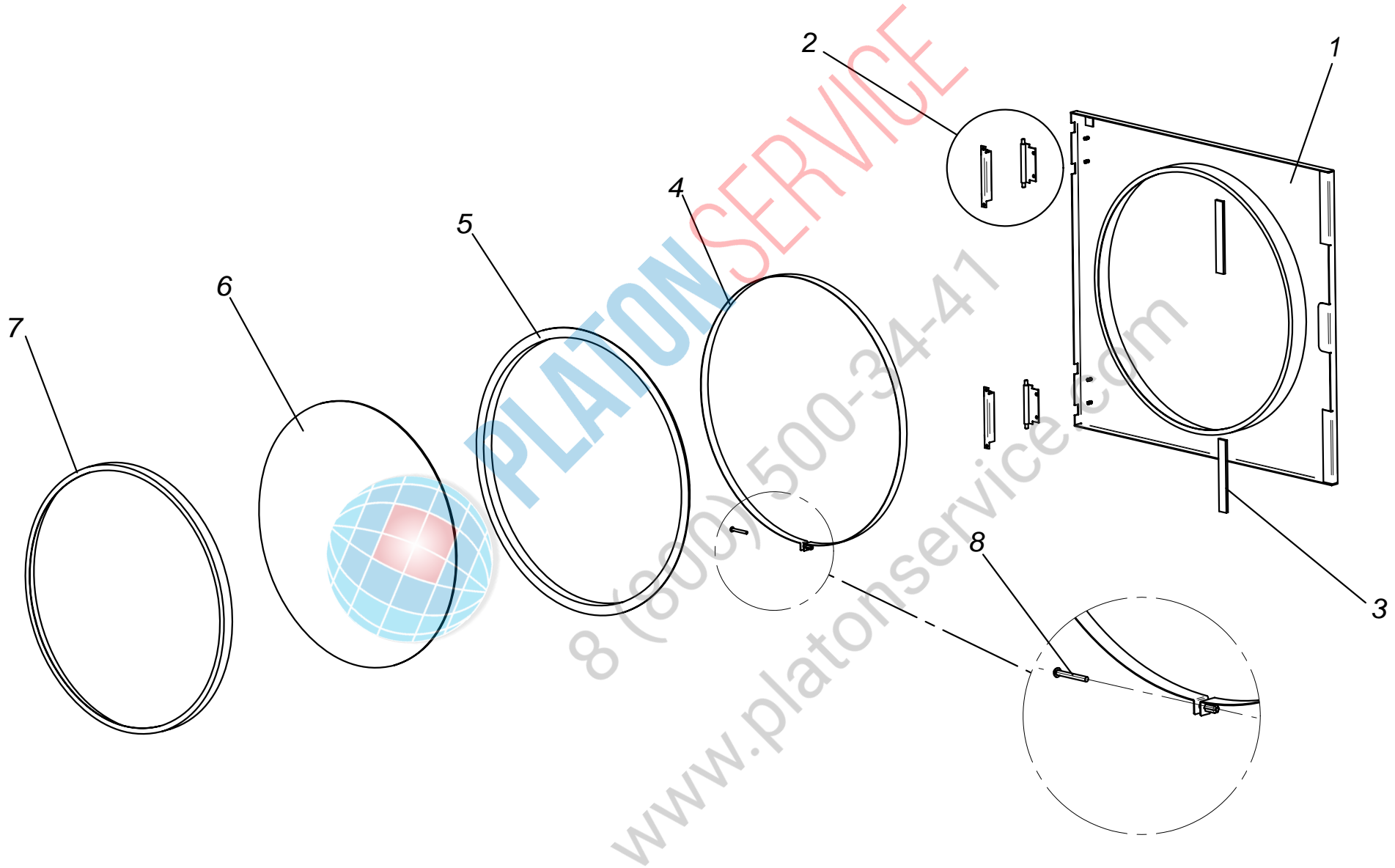

DOOR / PUERTA / PORTA / PORTE / TÜR FAGOR

Pos.	Código	23	Description	Descripción	Descrizione	Désignation	Bezeichnung
1	DO000Y0209	1	Door set	Conjunto puerta	Telaio oblò	Ensemble porte	Tür kompl.
2	DO1FB03040	2	Hidden hinge	Bisagra oculta	Cerniera oblò	Charnière cachée	Scharnier versteckt
3	DO1FB02219	2	Door locking magnet	Cierre magnético puerta	Oblò che blocca magnete	Fermeture magnétique porte	Tür die magneter verriegelt
4	DO1FB02219	1	Restraint ring	Aro de Sujeción	Anello di serraggio	Bage de serrage	Klemmring
5	DO1BE03411	1	Rubber profile	Perfil goma	Profilo in gomma	Profil de caoutchouc	Gummiprofil
6	DO1BG06036	1	Door glass	Cristal puerta	Vetro oblò	Vitrage porte	Türglas
7	DO010Y0030	1	Door glass ring	Aro soporte cristal puerta	Anello supporto vetro oblò	Anneau support vitrage porte	Haltering türglas
8	DO1TK20540	1	Screw	Tornillo	Vite	Visser	Schraube



PLATON SERVICE
 8 (800) 500-34-34
www.platonservice.com

EXHAUST / VENTILACION / ASPIRAZIONE / VENTILATION / LÜFTUNG

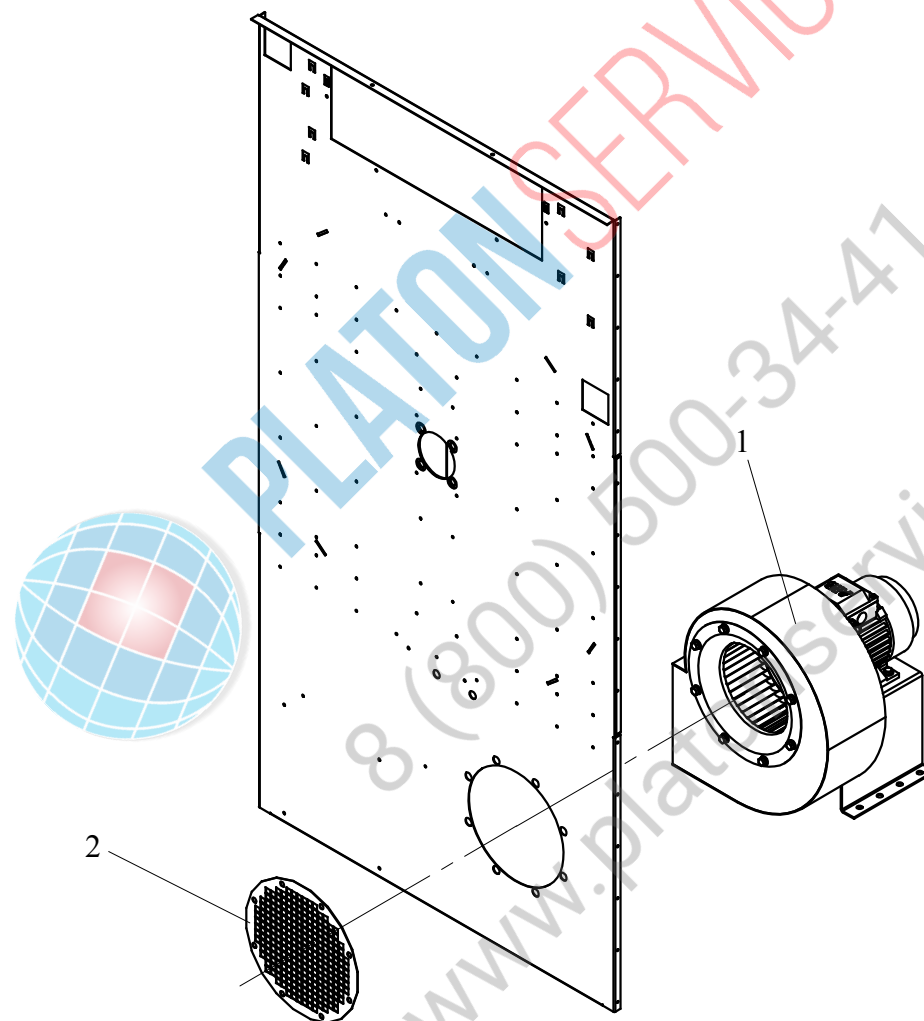

EXHAUST / VENTILACION / ASPIRAZIONE / VENTILATION / LÜFTUNG

ELECTRICAL HEATING / CALEFACCION ELECTRICA / RISCALDAMENTO ELETTRICO / CHAUFFAGE ELECTRIQUE / ELEKTRISCHE HEIZUNG

Pos.	Código	23	Description	Descripción	Descrizione	Désignation	Bezeichnung
1	DO1DE08317	1	Centrifugal fan 220 I	Ventilador centrífugo 220 I	Motoventilatore 220 I	Ventilateur centrifuge 220 I	Zentrifugalventilator 220 I
	DO1DE08315	1	Centrifugal fan 220 III	Ventilador centrífugo 220 III	Motoventilatore 220 III	Ventilateur centrifuge 220 III	Zentrifugalventilator 220 III
2	DO000Z4208	1	Fan protection	Rejilla ventilador	Piastra protezione ventilatore	Protecteur ventilateur	Ventilatorgitter



PLATON SERVICE
 8 (800) 500-34-41
www.platonservice.com

DRUM / TAMBOR / CESTO / TAMBOUR / TROMMEL

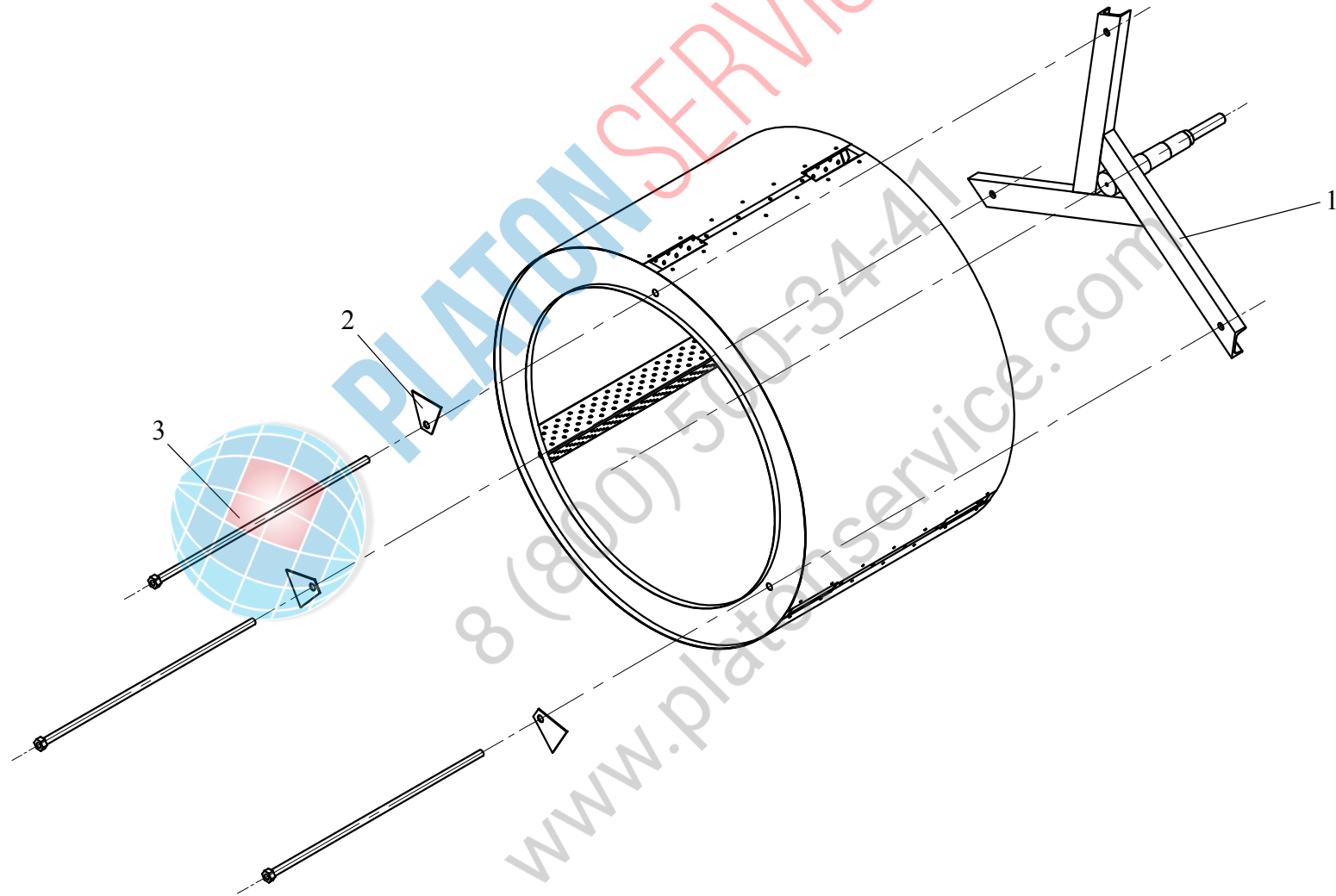

DRUM / TAMBOR / CESTO / TAMBOUR / TROMMEL (PAG.6)

Pos.	Código	23	Description	Descripción	Descrizione	Désignation	Bezeichnung
1	DO00V21001	1	Axle-radius set	Conjunto eje-radios tambor	Albero completo di raggi	Ensemble axe-rayons	Achse-Speicher-Satz
2	DO00V21016	3	Drum reinforcement	Refuerzo tambor	Placca rinforzo cesto	Renforcement tambour	Trommelverstärkung
3	DO00V21017	3	Drum suspender M12	Tirantes tambor M12	Tirante cesto M12	Tenseur tambour M12	Trommelspanvorrichtung M12



PLATON SERVICE
 8 (800) 500-34-41
www.platonservice.com

DRIVE / TRANSMISION / TRANSMISSIONE / TRANSMISSION / ÜBERTRAGUNG

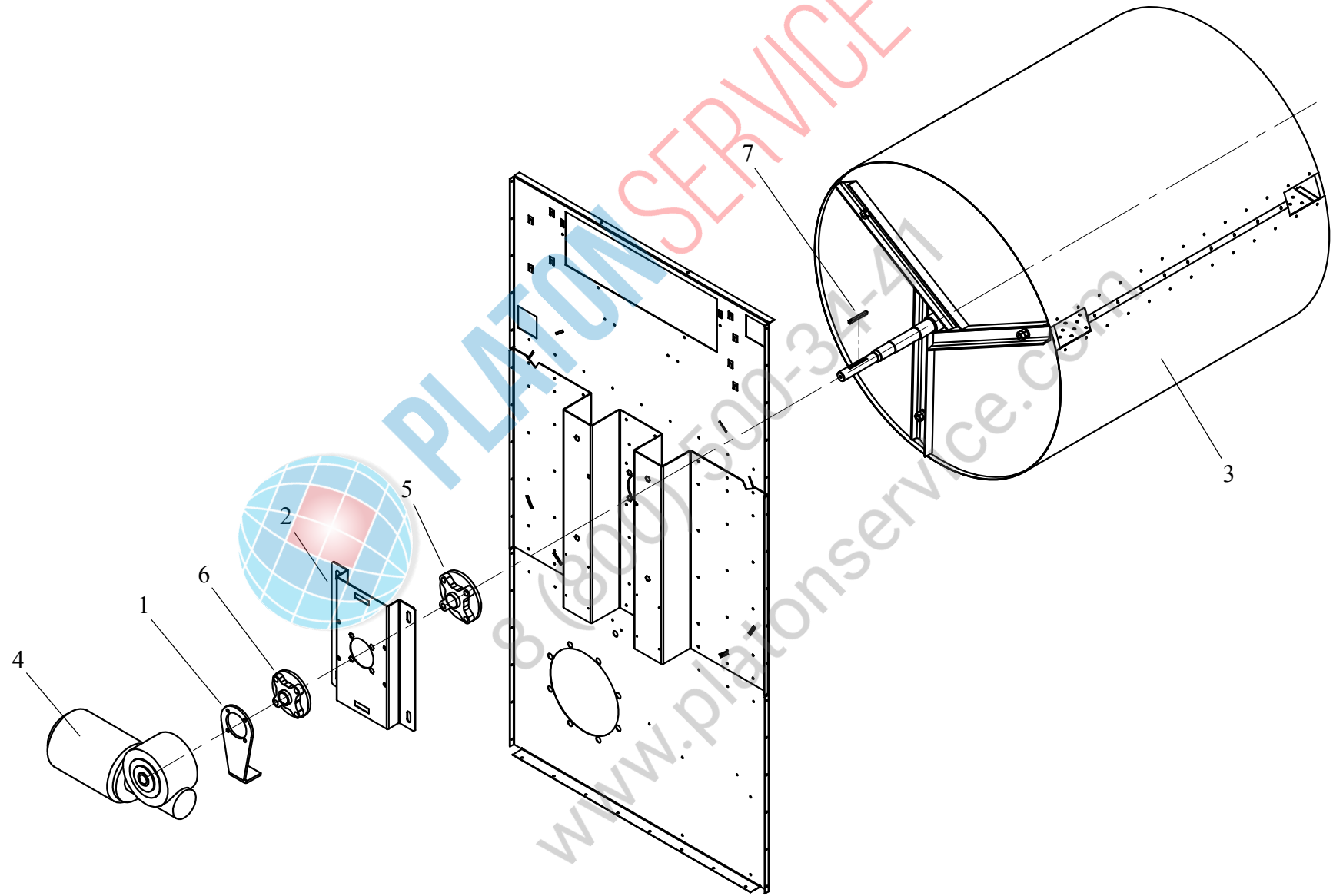

DRIVE / TRANSMISION / TRANSMISSIONE / TRANSMISSION / ÜBERTRAGUNG (PAG.8)

Pos.	Código	23	Description	Descripción	Descrizione	Désignation	Bezeichnung
1	DO00V20078	1	Torque arm	Brazo de reacción reductor	Braccio blocca riduttore	Bras contre couple	Rückwirkungsarm
2	DO00V20079	1	Bearing support	Soporte rodamiento	Piastra supporto sede cuscinetti	Support roulement	Lagersitz
3	DO01V21019	1	Drum set 23	Conjunto tambor 23	Cesto 23	Ensemble tambour 23	Trommel kompl. 23
4	DO1DC07048	1	Gearbox motor	Motoreductor	Motore riduttore	Moteur reducteur	Motor reduktionsgetriebe
5	DO1ED40206	1	Bearing UCFC 206	Rodamiento UCFC 206	Cuscinetto con sede UCFC 206	Roulement UCFC 206	Lager UCFC 206
6	DO1ED40207	1	Bearing UCFC 207	Rodamiento UCFC 207	Cuscinetto con sede UCFC 207	Roulement UCFC 207	Lager UCFC 207
7	DO1GX10068	1	Key 8x7x60	Chaveta 8x7x60	Linguetta albero cesto 8x7x60	Clavette 8x7x60	Keil 8x7x60



PLATON SERVICE
 8 (800) 500-34-44
 www.platonservice.com